



Technical information

Information technique
Información técnica
Technische Information
Informazione tecnica

QUARTZ

CALIBRE 5035

CALIBRE 5055



Technical Information
For the user
of the
product

ROLEX
CALIBRE

CALIBRE 5035

CALIBRE 5055



CONTENTS

Characteristics of calibre 5035	4
Characteristics of calibre 5055	5
Functions of the handsetting stem	6
List of special Rolex tools	6
Partial service of the calibre 5035/55	7-10
Opening the case	7
Checking the battery voltage in place	7
Changing the battery	7-8
Checking and adjusting the frequency of the quartz with the trimmer	8-9
Changing the dial	9-10
Changing the Day-Date indicators	10
Working principles of the Rolex Quartz movement	11
Complete service of the calibre 5035	12-22
Dismantling	12-13
Diagram of the motor	14
Cleaning of the motor	15
Lubricating chart	16
Reassembling of the movement	17-20
Reassembling of the date indicator mechanism	20-21
Correcting the endshake of the mounted date wheel of calibre 5035 and the cam with cannon, calendar wheel and calendar finger, of calibre 5055	22
Casing up	22
Complete service of the calibre 5055	23-26
Dismantling	23
Reassembling of the movement	17-20
Reassembling of the calendar mechanism	24-26
Recapitulation of tests	27
Steps to follow for frequency adjustment and search for reasons of breakdowns	28-29
Technical reminder connected with the Rolex Quartz movement	30-31



CALIBRE 5035

DATE INDICATOR MECHANISM – principle identical with that of calibre 3035

Rapid date corrector

Centre second hand jumping forward every second

Rolex mobile frame step-by-step motor

Stop-second device

– Overall diameter	29.75 mm
– Case-fitting diameter	29.00 mm
– Overall height	6.35 mm
– Number of jewels	11
– Frequency of quartz	32'768 Hz
– Integrated electronic circuit	C-MOS
– Output: polarized pulses	1 pulse/s.
– Duration of impulse	9.8 ms
– Silver oxyde battery	1.55 V
– Service life of battery	over 24 months
– Adjustment by trimmer	$\approx \pm 2$ s/d
– State (loss or gain) when worn in normal conditions after 1 year	less than 1 min.
– Operating range	$- 5^{\circ} \text{ C} + 55^{\circ} \text{ C}$
– Operating in magnetic fields up to about	1000 Oe

Movement seen from above (Fig. 1) and from below with date indicator (Fig. 2).

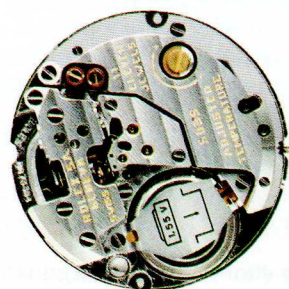

Fig. 1

Scale
1.25: 1

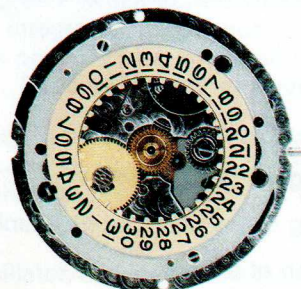

Fig. 2



CALIBRE 5055 - derived from calibre 5035

DAY-DATE CALENDAR MECHANISM – principle identical with that of calibre 3055

Rapid date corrector

– Overall diameter	29.75 mm
– Case-fitting diameter	29.00 mm
– Overall height	7.11 mm

Movement seen from below with Day-Date calendar mechanism (Fig. 3) and without indicators (Fig. 4).

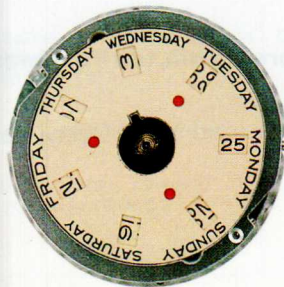

Fig. 3

Scale
1.25: 1

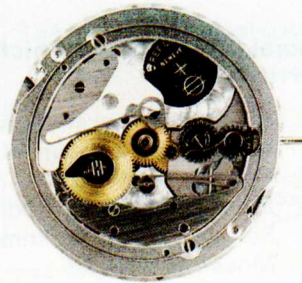

Fig. 4



CALIBRES 5035 and 5055

Functions of the handsetting stem

Position 1:
crown unscrewed



no function

Position 2:
crown pulled out
to first catch



backward motion:
correction of
date indication

forward motion:
no function

Position 3:
crown pulled out
to second catch



stop-second
(no current supply
to motor)

setting to time

crown pushed in: restarting of the motor with reset function; the second hand starts up after exactly one second.

The battery consumption is strongly reduced when the crown is in position 3, because only the electronic module and the quartz remain fed. Therefore, the watches must be stored with the crown pulled out to the second catch.

List of special ROLEX tools which can be ordered from the Technical Information Department

- Ref. 1009 Tool for taking off Oyster bezels (can be used for all Oyster bezels)
- 2003 * Key for calendar-wheel nut
- 2004 * Tool for extracting the cam stud
- 2005 ** Reamer for the day indicator
- 2023 Screwdriver for the trimmer
- 2024 Movement-holder

* Same tool as for calibres 1556-1575, 3035-3075

** Same tool as for calibres 1556, 3055



PARTIAL SERVICE OF THE CALIBRES 5035 and 5055

1. Opening the case

The back can be untightened without removing the bracelet from the case by means of a ROLEX Oyster opener Ref. 1001, 1003 or 1008, with jig. Ref. 1008/11.

No scraps of metal or dust must penetrate the watch; if necessary, clean the case before opening it.

- 1.1 Withdraw the spring lug from the clasp to separate the two parts of the bracelet.
- 1.2 Unscrew the back of the case.

2. Checking the battery voltage in place

Measure the voltage of the battery with a voltmeter or any instrument equipped with a voltmeter:

- 2.1. Place the positive voltmeter test lead terminal on the movement, for example in the notch of the screw for case and the negative terminal on the top side of the battery (Fig. 5). The voltage must be at least 1.55 volt.

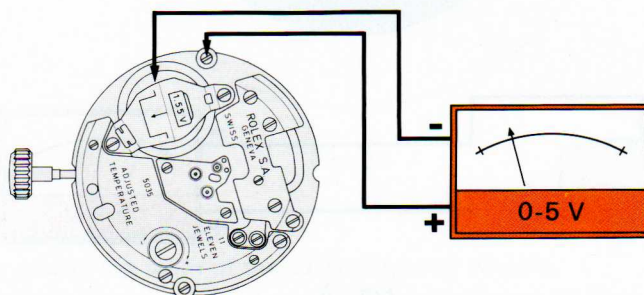

Fig. 5

3. Changing the battery

Use non-magnetic tweezers for the movement and plastic tweezers for the battery.

- 3.1. Remove the two screws of the battery bridge (No. 56013) and withdraw the bridge (No. 6013) with its printed circuit (No. 6012) which may fall out from it. Unscrew or tighten the screws one by one so that they are not drawn into the motor by the magnets.
- 3.2. Check the appearance of the printed circuit which is housed under the bridge; it should be changed if there are traces of oxidation.

Proceed as follows when putting the printed circuit back in place:

- Insert the little tongue of the circuit, with the metalised side of the circuit on the same side as the battery, in the corresponding aperture of the bridge.
- Press gently, with a leather buff, on the centre of the circuit and slide the circuit under the two protruding tongues of the bridge (Fig. 6).

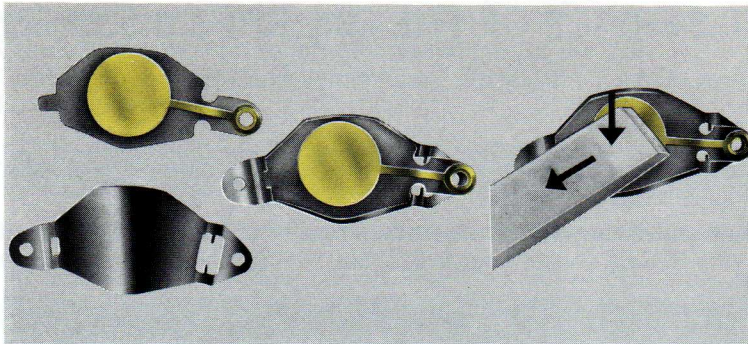

Fig. 6

- 3.3. Remove the used battery (No. 6014) by turning over the movement.
- 3.4. Check that the battery housing is clean.
- 3.5. Check the appearance of the new battery.

It should not be distorted in any way and the gasket should be clean and free of any traces of white crystals or yellowish liquid.

- 3.6. Check its voltage which must be at least 1.55 volt (Fig. 7).

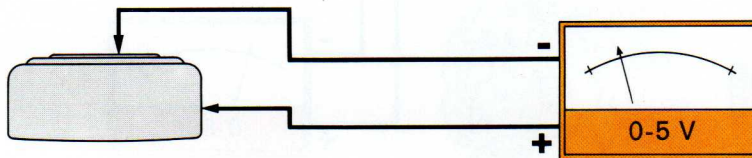

Fig. 7

- 3.7. Insert the battery with the positive (+) side at the bottom of the housing.
- 3.8. Replace the battery bridge.

Use only genuine ROLEX-packaged battery.

Never touch the battery with the fingers, use plastic tweezers to avoid short circuits.

Store the battery in a dry and cool place, but never in the refrigerator.

A number of three figures indicating the date of manufacture is marked on the rim of the battery. The first two figures refer to the month and the third one to the last figure of the year.

4. Checking and adjusting the frequency of the quartz with the trimmer

- 4.1. Check the daily rate of the watch on a timing machine for quartz watches.



- 4.2. Make any correction that may be necessary by turning the screw of the trimmer (Fig. 8) in the corresponding direction with the ROLEX tool Ref. 2023. The trimmer is a rather fragile element therefore only press gently on it.

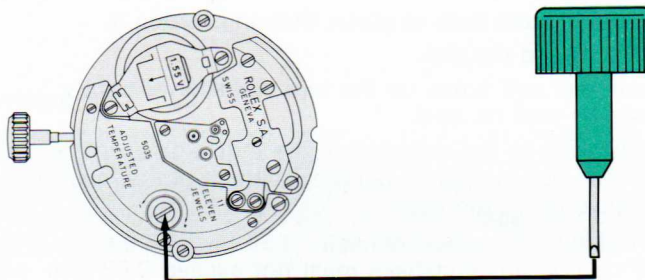

Fig. 8

The progression of the correction is not linear and the extent of the angle of the adjustment to be made depends on the position of the trimmer at the start. So turn the screw of the trimmer gently and only a few degrees at a time. When the maximum fast or slow point is reached, the correction operates in the opposite direction.

If the correction required is greater than can be made with the trimmer, $\approx \pm 2$ s/d, it will be necessary to change the electronic module.

However it should be noted that a loss of several seconds, which does not show up on a timing machine, can be the result of intermittent stopping (loss of seconds). In this case proceed as indicated on page 28, paragraph "Watch stops, second hand vibrates but does not move forward, or loss of seconds".

IMPORTANT

The temperature inversion point of the quartz is at $26 \pm 2^\circ \text{C}$. Our watches are adjusted to the temperature of the watch when worn, which is around 28°C . Temperatures below or above the inversion point will make the watch lose time, as illustrated in the diagram below (Fig. 9).

However, if the temperature when the watch is worn is noticeably different from normal, information from the customer should be sought before making the adjustment.

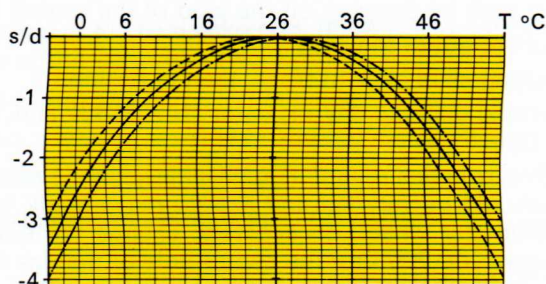

Fig. 9

5. Changing the dial

If a customer wishes to have a different * dial, proceed as follows:

* The indicators should match the colour of the new dial; if necessary change these. For the changing of Day-Date indicators see page 10, § 6.



- 5.1. Pull out the button to the second catch (position 3) to stop the movement and remove the handsetting stem by pressing on the stud of the setting lever.
- 5.2. Take the movement out of the case.
- 5.3. Put the handsetting stem back in place, then in position 3.
- 5.4. Take off the hands and the dial.
- 5.5. Put on the new dial and screw up the two dial screws tightly.
The dial should be well centred.
A slight modification to the centring of the indicator(s) in the aperture(s) of the dial can be carried out by slightly bending the arm of the respective jumper to give a different orientation to the beak.
- 5.6. Check the endshake of the hour wheel.
For the 5055 calibre, this endshake must not exceed 0.03 mm; hour wheel seats Nos. 5123-1, 5123-2, 5123-3 and 5123-4 (thickness: 0.02, 0.03, 0.04 and 0.05 mm) limiting the endshake are available.
- 5.7. Fit the hour and minute hands so that the date, respectively the day, change at midnight. Tolerance: $-1 +2$ minutes.
- 5.8. The second hand should be fitted as follows:
 - Push it down with slight pressure only.
 - Check its alignment with the minute-circle for one revolution.
 - Correct any misalignment by pushing the hand laterally, without forcing it.

The second hand must be correctly in line with the minute-circle of the dial.

- Drive the hand in perpendicularly all the way and again check alignment.

If alignment is no longer correct after the hand has been driven in all the way, it can no longer be displaced laterally without causing serious damage to the escapement; in such a case, therefore, the second hand must be removed and the driving-in operation recommenced.

6. Changing the Day-Date indicators

If a customer wishes to have the day indicator in another language, proceed as follows:

- 6.1. Pull out the button to the second catch (position 3) to stop the motor and remove the handsetting stem by pressing on the stud of the setting lever.
- 6.2. Take the movement out of the case.
- 6.3. Put the handsetting stem back in place, then in position 3.
- 6.4. Take off the hands, dial and day indicator (No. 5135) and, if applicable, also the date indicator (No. 5134).
- 6.5. Put on the new day indicator and, if applicable, also the new date indicator.
The indicator should be very flat and able to move freely, without any sideshake on the assembled star wheel. If necessary, enlarge the size of the centre-holes; use a Rolex reamer ref. 2005 for the centre-hole of the day indicator.
The indicators should fall freely when the movement is turned over. To fit the dial and hands proceed as instructed on page 9 and 10 § 5.5. and the following.
Correcting an imperfect change of date and day:
 - If an indicator jumps too far: strengthen the tension of the corresponding jumper.
 - If an indicator does not jump far enough: reduce the tension of the corresponding jumper (for correct tension of jumpers see page 25, Fig. 22).



WORKING PRINCIPLES OF THE ROLEX QUARTZ MOVEMENT

I. Power source

Battery 1.55 V

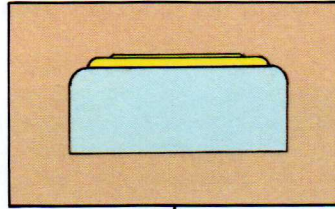

II. Electronic module

Integrated circuit

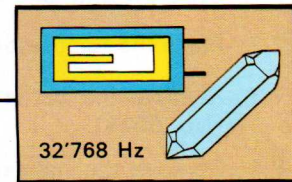
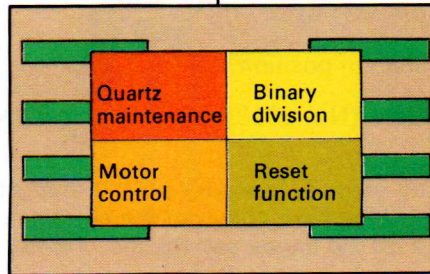

32'768 Hz

Quartz resonator

III. Transducer

ROLEX
Step-by-step motor

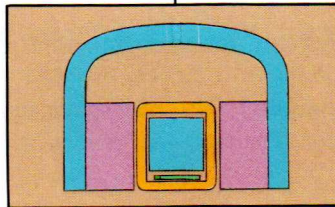

IV. Analog display

Train
and
hands

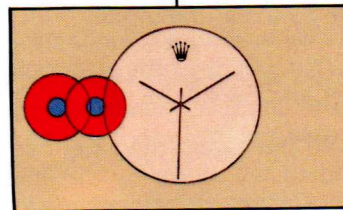



COMPLETE SERVICE OF THE CALIBRE 5035

7. Dismantling

Do not put the following components in the cleaning baths: electronic module (No. 6005), motor (No. 6011), printed circuit (No. 6012), battery bridle (No. 6013), battery (No. 6014), date indicator (No. 5099). These parts can be cleaned with cleaning paste.

The pallet fork can be put in the cleaning machine if it is fixed in a protective holder Ref. 3000 (pallet forks are delivered in this holder).

- 7.1. Unscrew and take off the case back.
- 7.2. Place the handsetting stem in position 1.
- 7.3. Remove the battery bridle (No. 6013) with its circuit (No. 6012) and battery (No. 6014).
- 7.4. Remove the handsetting stem by pressing on the stud of the setting lever and take the movement out of the case, then put the handsetting stem back in place, then in position 3. Take off the hands and the dial. Tighten the dial screws again.
- 7.5. Turn the bolt and remove the date indicator (No. 5099).
- 7.6. Remove the date indicator seating (No. 5098).
- 7.7. Remove the date jumper (No. 5095).
- 7.8. Remove the calendar wheel nut (No. 5093)—left-hand thread—with the ROLEX key Ref. 2003.
- 7.9. Remove the date wheel mounted (No. 5094) by slightly disengaging the cam yoke (No. 6044).
- 7.10. Remove the cam yoke with its jewel (No. 95090) by disengaging the cam yoke spring (No. 5091).
The cam yoke spring should be left in place.
- 7.11. Remove the hour wheel (No. 6024) and the cannon-pinion (No. 6025).
- 7.12. Remove the two gilt connecting screws (No. 56011-3) and the two exterior bridge screws (No. 56011-2) fixing the motor.
- 7.13. Take off the upper bridge (No. 6003) of the electronic module by unscrewing the four screws (Nos. 56005-1 and 56005-2).
- 7.14. Position the movement with the handsetting stem at 6 o'clock (Fig. 10), tip the pallet fork to the left, holding the motor by the armature take it off by raising it carefully; make sure that the spiral wires do not touch the pallet fork and get bent.

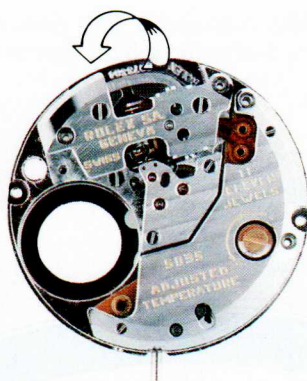

Fig. 10

Cleaning the motor: see page 15.

Place the motor, which has powerful magnets, out of reach of the metal parts.

- 7.15. Take out the electronic module (No. 6005) and the lower bridge of the module (No. 6004) by turning the movement over.
- 7.16. Take out the train bridge (No. 6001).
- 7.17. Take out the second wheel (No. 6023), the pallet fork (No. 6041) and the third wheel (No. 6022).
- 7.18. Take out the centre bridge (No. 6002) and the centre wheel (No. 6021).
- 7.19. Take out the jumper for setting lever, mounted (No. 6043), the minute wheel (No. 6026), the setting wheel (No. 6027), the yoke spring (No. 5041), the yoke (No. 5039), the handsetting stem (No. 5025), the sliding pinion (No. 6028) and the handsetting pinion (No. 6029).

The setting lever mounted (No. 6042) and its spring (No. 5037) should be left in place.



DIAGRAM OF THE MOTOR

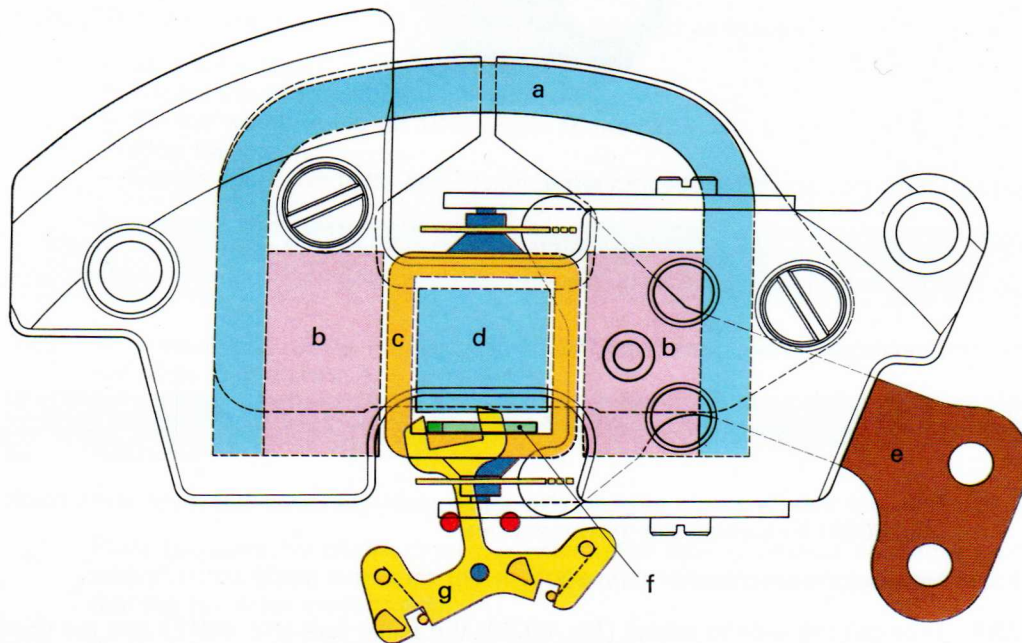

- a) Metal carcass
- b) Permanent magnets
- c) Mobile frame
- d) Core
- e) Printed circuit
- f) Finger
- g) Pallet fork



8. Cleaning the motor No. 6011 (Fig. 11)

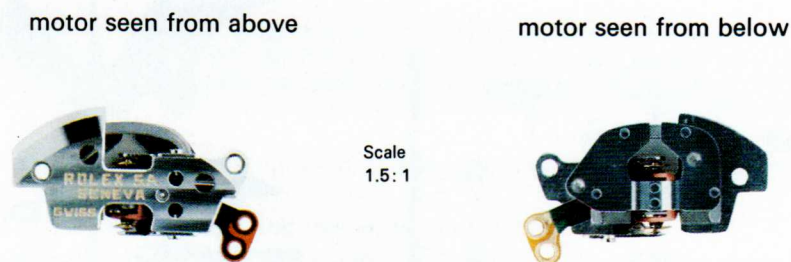

Fig. 11

The pivots of the mobile frame being not oiled, the motor does not require periodical cleaning. However it is important to make sure that no scraps of metal stick to the motor.

The components of the motor cannot be obtained separately.

- 8.1. Take off the two screws of the upper bridge, turn the module over.
- 8.2. Separate the lower bridge from the upper bridge, being careful not to damage the coil and the permanent magnets.
- 8.3. Remove one of the lateral bridges, unscrewing its screw.
- 8.4. Remove the printed circuit with the coil, unscrewing the screw.
- 8.5. Clean the pivots of the mobile frame (hold it by its finger) and the jewels of the lateral bridges.

The condition of the surface of the pivots does not affect the performance of the motor.

- 8.6. Carefully clean the stator (permanent magnets and core) with cleaning paste.
- 8.7. Reassemble the motor without oiling the pivots of the mobile frame.



OILING CHART

Movement

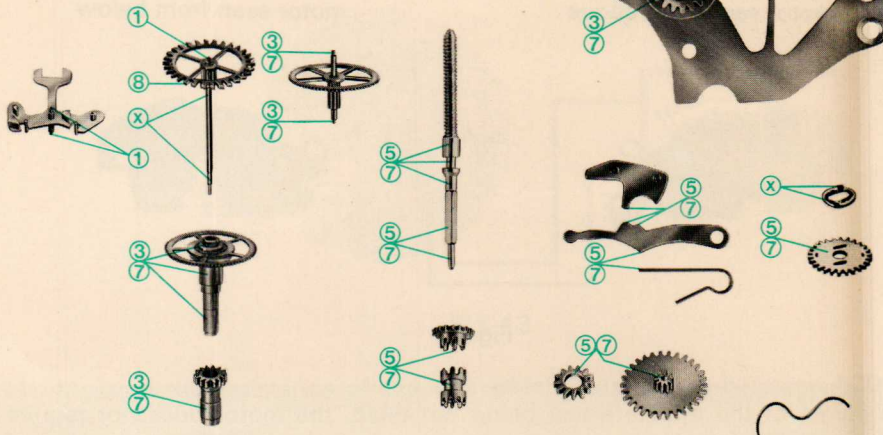

Date mechanism

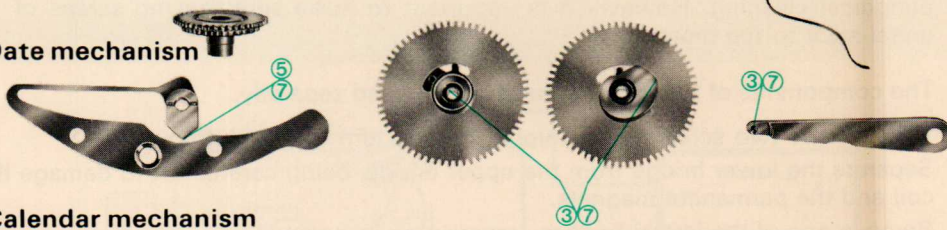

Calendar mechanism

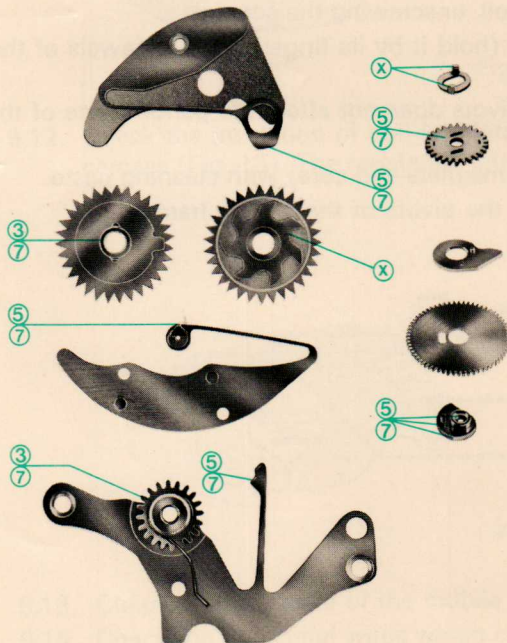

- ① SYNT-A-LUBE 9010
- ③ PML 163
- ⑤ Grease MR 2 or KT 22
- ⑦ FHMR 3
- ⑥ Grease Moebius 9415
- ⊗ Do not oil
- △ Do not dismantle

The lubricants ③ and ⑤ can be replaced by the oil ⑦.

These oils and greases can be ordered from the Technical Information Department



9. Reassembling of the movement

For lubrication, see diagram on page 16.

Make sure that all screws are tight, but do not force the motor connecting screws (No.56011-3) otherwise this could damage the printed circuit.

- 9.1. Grease and fit the handsetting stem, the handsetting stem pinion and the sliding pinion.
- 9.2. Oil and fit the centre wheel and the centre bridge.
- 9.3. Oil the pivot-shank of the centre wheel, the setting wheel and the minute stud.
- 9.4. Fit the cannon pinion, the setting wheel and the minute wheel.
- 9.5. Fit the yoke, the yoke spring and the mounted jumper for the setting lever and check the friction of the cannon pinion.
- 9.6. Fit the third wheel, lightly oil the shoulder on the pinion side of the second wheel and put it in place, oil the lower pivot of the pallet fork, fit the latter with the bridge, then check the endshakes.

The two pins fixed to the movable blades have been carefully positioned in the factory. Their position should on no account be modified because it determines the regularity with which the second hand jumps and the performance of the escapement.

- 9.7. Oil the lower and upper pivots of the centre wheel, the upper pivots of the second wheel and of the pallet fork.
- 9.8. Fit the lower bridge of the module and then the electronic module.
- 9.9. Check the stop-second function (Fig. 12).

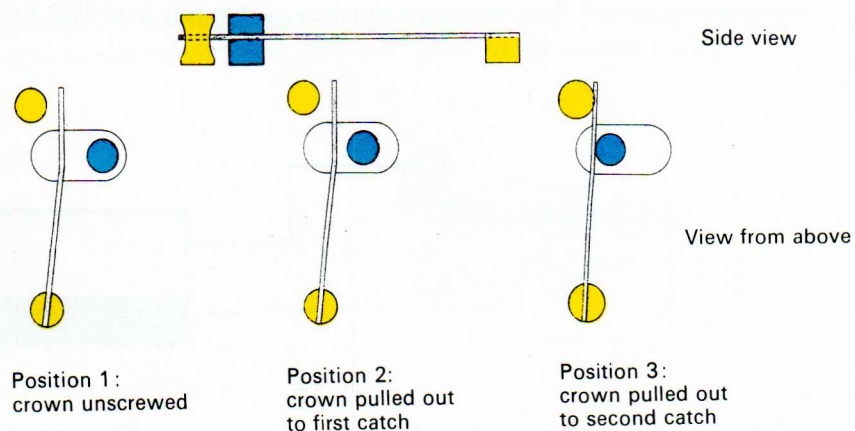

Fig. 12



9.10. Check whether there are impulses at the output of the electronic module (Fig. 13).

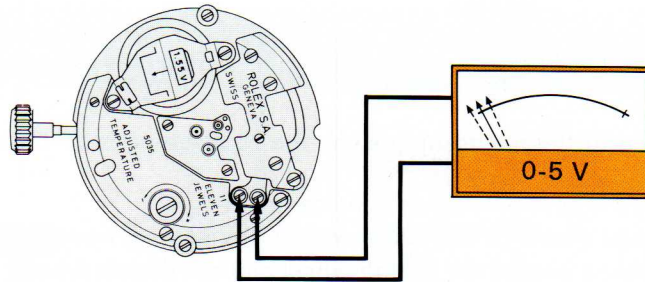

Fig. 13

9.11. Measure the resistance of the coil which must range between 1200-1500 Ω (Fig. 14).

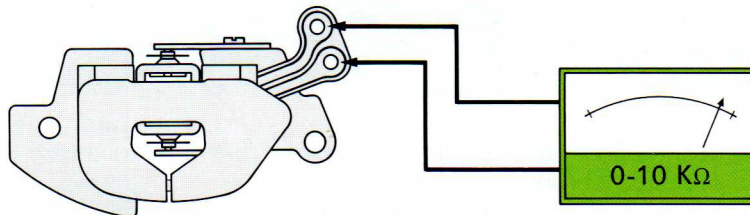

Fig. 14

9.12. Check the insulation of coil in relation to the finger and in relation to the metal carcass (Fig. 15). The resistance must be $>$ (bigger) than 100 K Ω .

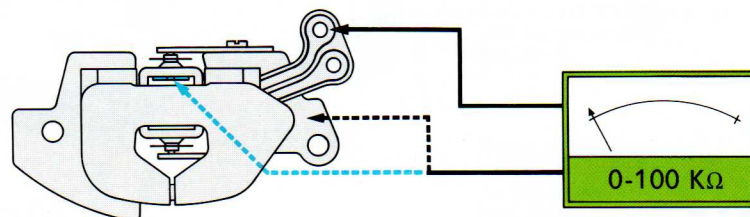

Fig. 15

9.13. Check the sideshake of the mobile frame.

9.14. Check the two spiral wires which convey the current to the coil. They should not touch one another.



- 9.15. Fit the motor after checking and a possible cleaning. Cleaning the motor see page 15. To fit the motor easier, tip the pallet fork and the finger to the left (Fig. 16).

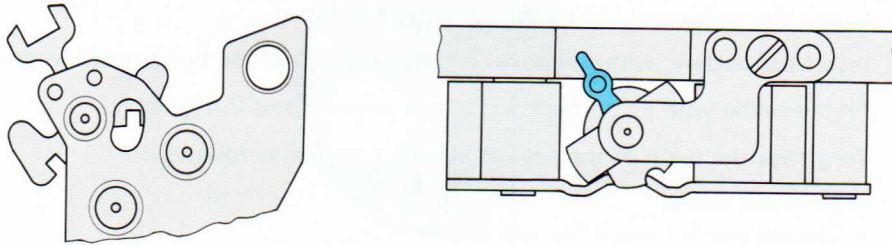

Fig. 16

- 9.16. Fit the upper bridge of the electronic module.
9.17. Screw up the two connecting screws.
9.18. Measure total consumption at a voltage of 1.55 V with the external supply stabilised (Fig. 17). It should be \leq to $9 \mu\text{A}$ (equal or smaller).

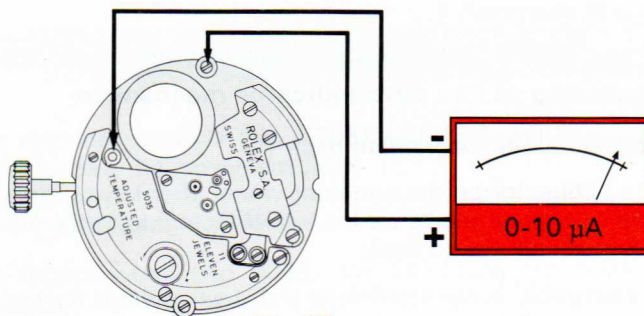

Fig. 17

- 9.19. Fit the handsetting stem in position 3 (no current supply to motor) and measure the consumption of the electronic module (Fig. 18) which should be \leq to $3 \mu\text{A}$.

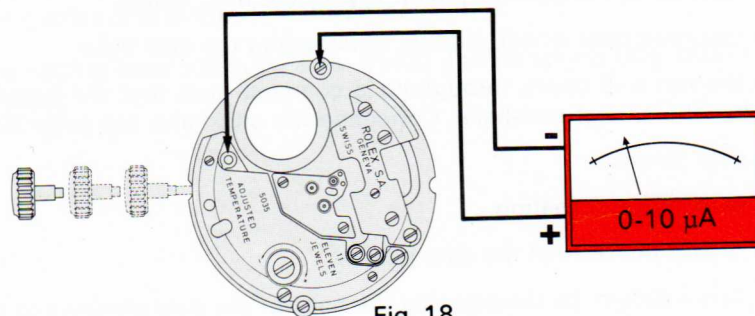

Fig. 18

* Damaged motors are exchanged at a special price at our Spare Parts Division.



- 9.20. After an overhaul use a new battery to ensure maximum running time.
The battery should not be distorted in any way and the gasket should be clean and free of any traces of white crystals or yellowish liquid.
- 9.21. Check the voltage of the battery, see page 8, Fig. 7.
- 9.22. Insert the battery, with the positive pole side (+) at the bottom of the housing.
- 9.23. Fit the bridle with its printed circuit, see pages 7 and 8, Fig. 6.
- 9.24. To grease the teeth of the second wheel, proceed as follows:
- Stop the watch.
 - Grease the five teeth that are visible.
 - Set the watch going for 10 seconds (5 teeth).
 - Stop the watch.
 - Grease again five teeth and continue the procedure for one turn of the wheel.

Each tooth should be lubricated and the quantity of grease required is substantially more than that needed for an escapement wheel of a mechanical watch.

- 9.25. If necessary, adjust the frequency at an ambient temperature approaching 28 ° C, see page 8, paragraph 4.

10. Reassembling of the date indicator mechanism

For lubrication, see diagram on page 16.

- 10.1. Place the corrector on the corrector wheel after having greased this latter one, with the two guide marks on the wheel facing upwards, put in place and check that the corrector moves freely.
- 10.2. Fit the cam yoke, its countersink for the jewel towards the dial side, by disengaging the spring of the cam yoke, then put in place the jewel for cam yoke.
- 10.3. Oil the cam yoke spring resting point on the cam yoke, the hole and the rim of the jewel of the yoke and the cam stud. Oil the pivoting point of the intermediate setting wheel fixed to the setting jumper.
- 10.4. Oil the outside of the cannon-pinion and fit the hour wheel.
- 10.5. Fit the mounted date wheel, slightly disengaging the cam yoke.
- 10.6. Screw the nut and check throughout a complete turn that the mounted date wheel has the correct endshake. Correcting the endshake, see page 22.
- 10.7. Fit the date jumper.
- 10.8. Fit the date indicator seating.
- 10.9. Lightly grease the beak of the date jumper.
- 10.10. Fit the date indicator by disengaging the beak of the date jumper and close the bolt.
- 10.11. Fit the dial and screw the two dial screws up tight.



10.12. Check the freedom and endshake of the hour wheel as well as the changing of the date.

Correcting a faulty changing of the date:

- The indicator jumps too far: strengthen the tension of the date jumper.
- The indicator does not jump far enough: reduce the tension of the date jumper.

Correct tension of the jumper, Fig. 19.

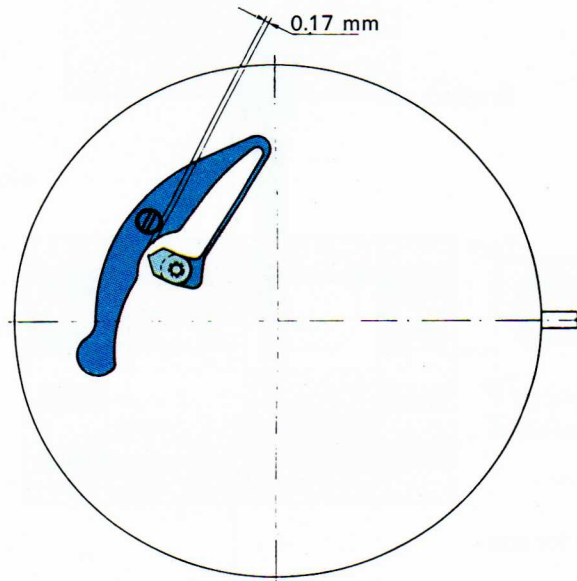

Fig. 19

To centre the date indicator position the eccentric or slightly bend the arm of the date jumper in order to position the beak.

10.13. Press in the hour and minute hands, preferably on a ROLEX movement holder Ref. 2024, in such a way as to ensure that the date changes at midnight. Tolerance $-1 +2$ minutes.

10.14. Press in the second hand slightly.

- Check its alignment throughout one full turn of the dial.
- Correct any possible misalignment by pushing the hand in a lateral direction but without forcing it.

The second hand should line up well with the minute-marks on the dial.

- Press the hand well home perpendicularly and check the alignment again.

If the alignment is no longer correct after the hand has been pressed home, the hand cannot be moved laterally without seriously damaging the escapement; it will therefore be necessary to take the second hand off and start the process from the beginning again.

10.15. Re-check the change of date after casing up.



11. Correcting the endshake of the mounted date wheel of calibre 5035 and of the cam with cannon, calendar wheel and calendar finger of calibre 5055

The height of the cam stud (No. 5092) can be adjusted:

- By driving in the cam stud with a jewel fitting tool to reduce the endshake.
- By pulling out the cam with the ROLEX tool Ref. 2004 (Fig. 20) to increase the endshake.

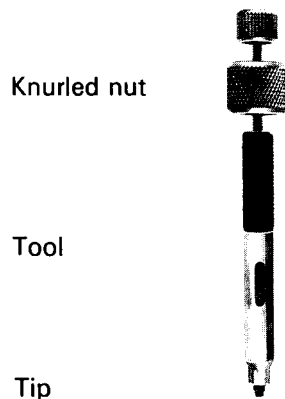

Fig. 20

Instructions for use

Screw – left-hand thread – the tip of the tool onto the cam stud.

Screw the knurled nut until it touches the tool and then, in spite of the resistance, go on turning slowly so as to extract the stud.

(1/8 of a turn = about 0.03 mm)

12. Casing up

12.1. Fit the movement into the case, which should have been previously reconditioned (polishing and satin-finishing of case and bracelet, testing for water-resistance). Insert the handsetting stem and screw the crown onto the tube in order to centre the movement.

12.2. Lock the case screws (No. 55053) by unscrewing them.

12.3. Screw on and tighten the case back, then carry out the final water-resistance test.

If the bezel has to be removed for the reconditioning of the case, it is recommended to use the ROLEX OYSTER bezel remover Ref. 1009.

The washer of the crystal must be changed if the bezel is removed.



COMPLETE SERVICE OF THE CALIBRE 5055

13. Dismantling

Do not put the following components in the cleaning baths: electronic module (No. 6005), motor (No. 6011), printed circuit (No. 6012), battery bridle (No. 6013), battery (No. 6014), day and date indicators (No. 5135 and 5134). These parts can be cleaned with cleaning paste.

The pallet fork can be put in the cleaning machine if it is fixed in a protective holder Ref. 3000 (pallet forks are delivered in this holder).

- 13.1. Unscrew and take off the case back.
- 13.2. Place the handsetting stem in position 1.
- 13.3. Remove the battery bridle (No. 6013) with its circuit (No. 6012) and the battery (No. 6014).
- 13.4. Remove the handsetting stem by pressing on the stud of the handsetting lever and take the movement out of the case, then put the handsetting stem back in place, then in position 3. Take off the hands and the dial. Tighten the dial screws again.
- 13.5. Remove the day and date indicators (Nos. 5135 and 5134).
- 13.6. Remove the assembled star wheels (No. 5131).
- 13.7. Remove the indicator seating (No. 6076).
- 13.8. Remove the day and date jumpers (Nos. 5136 and 5128).
- 13.9. Remove the calendar wheel nut (No. 5093) – left-hand thread – with the ROLEX key Ref. 2003.
- 13.10. Remove the calendar finger (No. 5132), the calendar wheel (No. 5127) and the cam with cannon (No. 5126) by slightly disengaging the cam yoke (No. 6044).
- 13.11. Remove the jewel of the cam yoke (No. 95090) and the cam yoke by disengaging the spring of the cam yoke (No. 5091).
The cam yoke spring should be left in place.
- 13.12. Remove the hour wheel (No. 6072) and the cannon pinion (No. 6074).
- 13.13. Remove the date corrector (No. 5129) and its wheel (No. 5097).
- 13.14. Dismantle the movement as indicated on paragraphs 7.12. to 7.18. pages 12 and 13.
- 13.15. Take out the jumper for setting lever, mounted (No. 6075), the minute wheel (No. 6026), the setting wheel (No. 6027), the yoke spring (No. 5041), the yoke (No. 5039), the handsetting stem (No. 5025), the sliding pinion (No. 6028) and the handsetting pinion (No. 6029).

The setting lever mounted (No. 6042) and its spring (No. 5037) should be left in place.



14. Reassembling of the movement

See pages 17-20.

15. Reassembling of the calendar mechanism

For lubrication, see diagram on page 16.

- 15.1. Check the tension of the corrector spring (Fig. 21) and the liberty of the corrector. The corrector spring is riveted to the jumper for setting lever mounted. Change the whole jumper if the spring does not work properly.

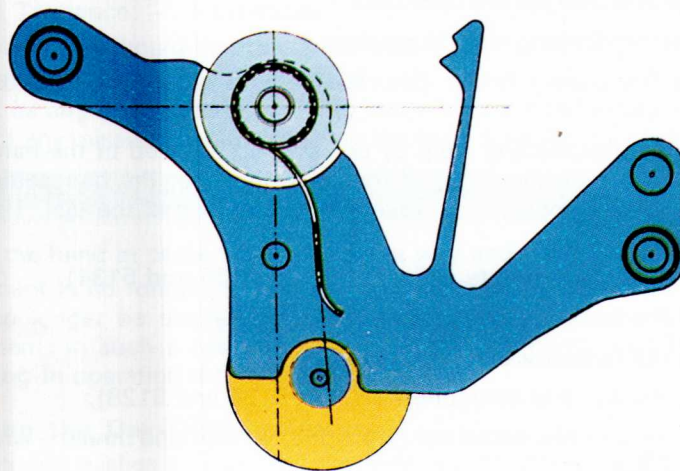

Fig. 21

- 15.2. Place the corrector on the corrector wheel after the latter has been greased, with the two guide marks on the wheel facing upwards, put in place and check that the corrector moves freely.
- 15.3. Fit the cam yoke, its countersink for the jewel towards the dial side, by disengaging the spring of the cam yoke, then put in place the jewel for cam yoke.
- 15.4. Oil the cam yoke spring supporting point on the cam yoke, the hole and the rim of the jewel of the yoke and the cam stud. Oil the pivoting point of the intermediate handsetting wheel fixed to the handsetting jumper.
- 15.5. Oil the outside of the cannon pinion and fit the hour wheel.
- 15.6. Fit the cam with cannon by slightly disengaging the cam yoke, the wheel and the calendar finger.



- 15.7. Screw the nut and check throughout a complete turn that the wheel and the calendar finger have the correct endshake. Correcting the endshake, see page 22.
- 15.8. Fit the date and day jumpers.
 - The arms of the two jumpers should be parallel to the plate.
 - The tension of the jumpers should correspond to the diagram Fig. 22.

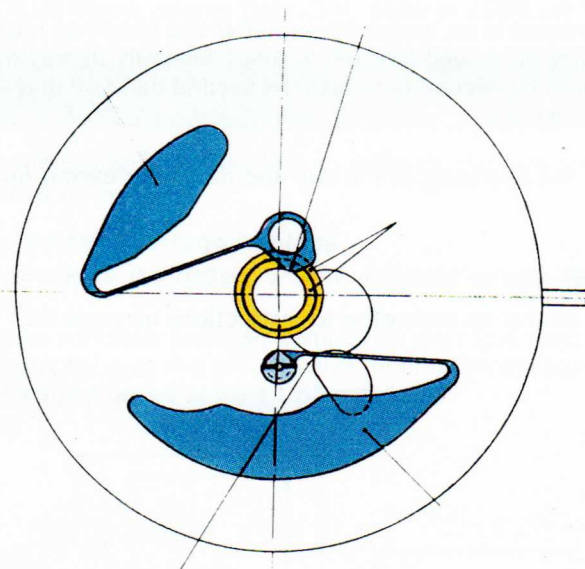

Fig. 22

- 15.9. Fit the indicator seating.
- 15.10. Lightly grease the teeth of the assembled star wheels.
- 15.11. Fit the assembled star wheels and see that the beaks of the jumpers engage the star wheels.
- 15.12. Fit the day and date indicators.
- 15.13. Fit the dial and screw the two dial screws up tight.
- 15.14. Check the freedom and endshake of the hour wheel which should not exceed 0.03 mm, see page 10, paragraph 5.6.
- 15.15. Check the changing of the day and date.
Correcting a faulty changing of the date and day:
 - The indicator jumps too far: strengthen the tension of the corresponding jumper.
 - The indicator does not jump far enough: reduce the tension of the corresponding jumper.
 - If it works badly, see page 10, paragraph 6.
- 15.16. Press in the hour and minute hands, preferably on a ROLEX movement holder Ref. 2024, in such a way as to ensure that the date and day change at midnight. Tolerance -1 +2 minutes.



15.17. Press in the second hand slightly.

- Check its alignment throughout one full turn of the dial.
- Correct any possible misalignment by pushing the hand in a lateral direction but without forcing it.

The second hand should line up well with the minute - marks on the dial.

- Press the hand well home perpendicularly and check the alignment again.

If the alignment is no longer correct after the hand has been pressed home, the hand cannot be moved laterally without seriously damaging the escapement; it will therefore be necessary to take the second hand off and start the process from the beginning again.

15.18. Re-check the changing of the day and date after casing up.

16. Casing up

Carry out casing up according to instructions on page 22.



RECAPITULATION OF TESTS

	Instrument	Measurement	Remarks
1. Voltage of battery (pages 7 and 8, Fig. 5 and 7)	Voltmeter	1.55 V min.	
2. Resistance of coil (mobile frame) (page 18, Fig. 14)	Ohmmeter	1200-1500 Ω	motor out of movement
3. Insulation of coil in relation to the finger and in relation to the metal carcass (page 18, Fig. 15)	Ohmmeter	> 100 K Ω	motor out of movement
4. Impulse at the output of the electronic module (page 18, Fig. 13)	Voltmeter	Oscillating movement of the hand	connected to terminals of motor (2 gilt screws)
5. Consumption of movement at stabilised voltage of 1.55 V (page 19, Fig. 17)	Current integrator	9 μ A max.	motor and electronic module
6. Consumption of electronic module at stabilised voltage of 1.55 V (page 19, Fig. 18)	Current integrator	3 μ A max.	handsetting stem in position 3, no current supply to motor
7. Adjusting frequency, powered by battery (pages 8 and 9, Fig. 8)	Timing machine	± 0.05 s/d	at temperature around 28° C, see page 9, § IMPORTANT



**STEPS TO FOLLOW FOR:
FREQUENCY ADJUSTMENT, DETECTION AND REMEDYING OF BREAKDOWNS,
BASED ON INSTANTANEOUS CHECK ON A TIMING MACHINE OR/AND CUSTOMER'S COMMENTS**

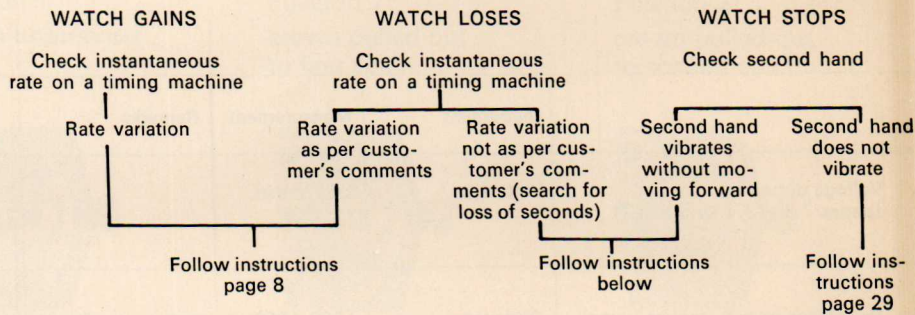

Watch stops, second hand vibrates but does not move forward or loss of seconds

Remove case back

n.o.k. = faulty
o.k. = not faulty

m.w. = movement works
m.n.w. = movement does not work

1. Check voltage of battery	n.o.k. → change battery o.k. → see 2) below	m.w. → see 6) below m.n.w. → see 2) below
2. Check handfitting	n.o.k. → correct handfitting o.k. → see 3) below	m.w. → see 6) below m.n.w. → see 3) below
3. Remove pallet fork and see if motor works	n.o.k. → overhaul or change motor o.k. → change pallet fork, possibly also second wheel	m.w. → see 6) below m.n.w. → see 4) below m.w. → see 6) below m.n.w. → see 4) below
4. Uncase and check freedom of train	n.o.k. → dismantle, clean, change the possibly defective part o.k. → see 5) below	m.w. → see 6) below m.n.w. → see 5, below
5. Check the date indicator/calendar mechanism and handsetting mechanism	n.o.k. → dismantle, clean, change the possibly defective part o.k. → see 6) below	m.w. → see 6) below m.n.w. → see 1) and start checking procedure again
6. Reassemble, case up, check and if necessary adjust the frequency. Screw on and tighten the case back and check water-resistance.		



Watch stops, second hand does not move at all

Remove case back

n.o.k. = faulty
o.k. = not faulty

m.w. = movement works
m.n.w. = movement does not work

1. Check voltage of battery, see p. 4	n.o.k. → change battery	m.w. → see 9) below m.n.w. → see 2) below
	o.k. → see 2) below	
2. Remove battery bridle and check its circuit	n.o.k. → change bridle circuit	m.w. → see 9) below m.n.w. → see 3) below
	o.k. → see 3) below	
3. Uncase, check handfitting	n.o.k. → correct handfitting	m.w. → see 9) below m.n.w. → see 4) below
	o.k. → see 4) below	
4. Check stop second function, see p. 17 Fig. 12	n.o.k. → correct function, possibly change electronic module	m.w. → see 9) below m.n.w. → see 5) below
	o.k. → see 5) below	
5. Check whether there are impulses at the output of the electronic module, see page 18 Fig. 13	n.o.k. → change electronic module	m.w. → see 9) below m.n.w. → see 6) below
	o.k. → see 6) below	
6. Remove the motor, see page 12, § 7.14., carry out the controls page 18, § 9.11. and 9.12. and make sure the motor is clean	n.o.k. → change the motor	m.w. → see 9) below m.n.w. → see 7) below
	o.k. → see 7) below	
7. Check the good condition and freedom of train and pallet fork	n.o.k. → dismantle, clean, change the possibly defective part	m.w. → see 9) below m.n.w. → see 8) below
	o.k. → see 8) below	
8. Check the date indicator/calendar mechanism and handsetting mechanism	n.o.k. → dismantle, clean, change the possibly defective part	m.w. → see 9) below m.n.w. → see 1) and start checking again
	o.k. → see 9) below	
9. Reassemble, case up, check and if necessary adjust the frequency. Screw on and tighten the case back and check water-resistance.		



TECHNICAL REMINDER CONNECTED WITH THE ROLEX QUARTZ MOVEMENT

Battery

The battery takes the place of the barrel in a mechanical watch. Whilst a large part of the power is used to make the mechanical parts of the movement move, the purely electronic functions require little power.

The large hands and the important safety factors of ROLEX watches require comparatively more power than other calibres. Because of this the battery selected is relatively big.

Apart from its size, voltage and theoretical capacity, there are other parameters to batteries which are not generally mentioned. This means that it is dangerous to use a different battery from the one recommended, even if it is called "an equivalent" by the supplier of a competitive brand.

Even the best of batteries is essentially the least reliable element of a movement. The only way of predicting how it will behave in a watch is to make statistical tests (e.g. for premature discharge) when it is selected.

Batteries should be stored in a dry place; humidity causes self-discharge.

At the present stage of technical development, silver oxide watch batteries cannot be guaranteed to be leak-proof after three years because the effects of aging on the part of the plastic which acts as a leak-proofness and insulating gasket are impossible to check.

Electronic module

As its name suggests, an electronic module groups together all the electronic parts of the watch, chief of these being the integrated circuit which controls the system. The parts which are associated with it but cannot be integrated are the quartz, which is the frequency standard, the trimmer, with which it is possible to make small corrections to the frequency, and the resetting contact.

The integrated circuit contains the following principal functions: the oscillator, which in association with the quartz and the trimmer produces the standard frequency, the divider, which converts it into a signal of 1 Hz (1 impulse per second) and the 1 Hz impulse amplifier, to the terminals of which the motor is connected.

The low consumption of the purely electronic oscillator/divider circuits makes them more vulnerable to any polluting agents accidentally deposited on certain of the connections of the integrated circuit, chiefly on those involving the quartz circuit. Therefore the electronic module should not be touched by hand and should not be washed.



Finally, it should be noted that the quartz resonator is as shock-resistant as other parts of the watch. Should there be a deviation caused by a big shock, any resulting alteration to the frequency can normally be corrected with the trimmer.

Motor

The motor, the second wheel and the pallet fork form the transducer. Every second the motor receives an impulse which makes the coil (mobile frame) rock at 45° alternatively in each direction. The finger fixed to the mobile frame transmits its power by means of the pallet fork to the second wheel bearing the second hand.

The movable pins of the pallet fork ensure that the second wheel is held 100 % tight and thus protected against shock. The finger has a little magnet which keeps the pallet fork at the banking until the next impulse.

